

Contact Information

Company Name: _____ Date: _____
 Contact Name: _____ Phone: _____
 Address: _____ Fax: _____
 _____ Email: _____

Workpiece and Production Volume

Detail: _____
 Quantity of tools: _____
 Volume of production: _____ pcs/year

Workpiece Material

Structural steel, good machinability Grey cast iron, malleable
 Hardened steel Nodular cast iron
 Tool steel Aluminum (<10% Si)
 Stainless steel Aluminum (>10% Si)
 Other _____ Copper, bronze

Coolant Supply

Through spindle
 Flood

Straight Shank DIN 6535

HA 
 HE 
 HB 

Material code	Tensile strength (N/mm ²)	Hardness (HRC, HB, HV,...)

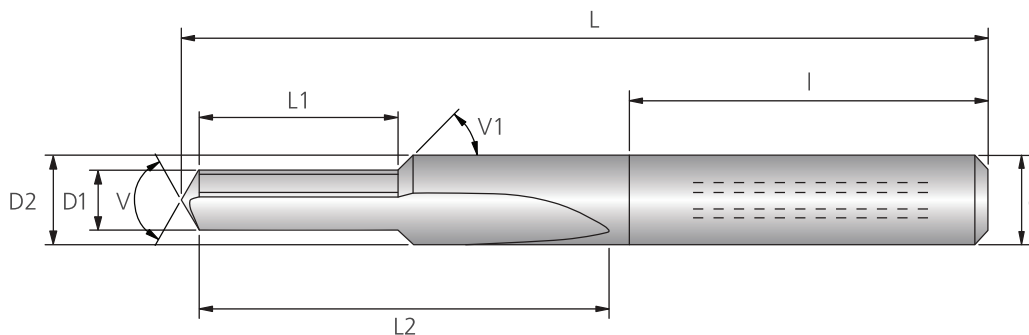

Tool Information - specify inch or metric

	Tool Dimension	Tool Tolerance	Workpiece Tolerance
D1 = Diameter			
D2 = Diameter			
d = Shank diameter			
L = Overall length			
L1 = Drilling depth			

	Tool Dimension	Tool Tolerance	Workpiece Tolerance
L2 = Drilling depth			
I = Shank length			
V1 = Chamfer angle			
V = angle is dependant on material being machined			

Please sketch workpiece below:

