

Pulley Spindle Dimensional Guide

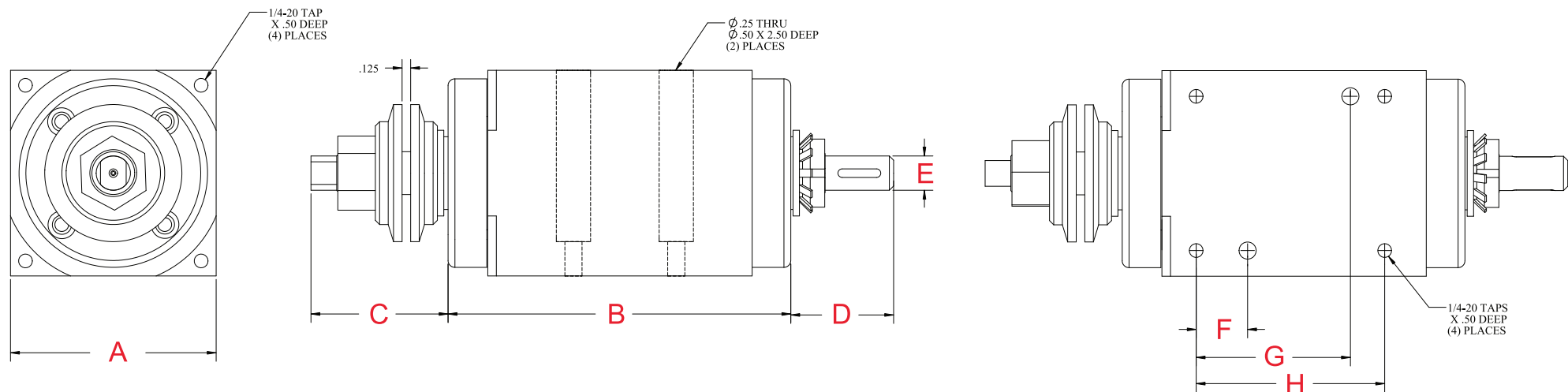

Standard Sizes	A (in)	B (in)	C (in)	D (in)	E (in)	F (in)	G (in)	H (in)
Spindle 104	3.00	5.00	2.00	1.50	0.50	0.750	2.250	2.750
Spindle 206	3.75	6.00	3.49	2.65	1.00	1.250	2.750	4.000
Spindle 208	4.375	6.50	3.49	2.65	1.00	1.250	3.250	4.500
Spindle 210	4.75	7.00	3.49	3.00	1.50	1.250	3.750	5.000
Spindle 212	5.5	8.00	3.49	3.00	2.00	1.250	4.750	6.000
Spindle 214	6.25	9.00	3.49	3.50	2.00	1.250	5.750	7.000
Spindle 217/214	7.5	17	8" Max	5" Max	2.25	1.5	11.0	12.5
Custom	To suit	To Suit	To Suit	To Suit	To Suit	To Suit	To Suit	To Suit

Proprietary & Confidential - The information contained in this drawing is the sole property of Ekstrom Carlson. Any reproduction in part or as a whole without the written permission of Ekstrom Carlson is prohibited.